

WOODS ROTARY MOWER

59LB-1

**For use on IH154, IH185 Cub LoBoy and IH184
(with or without 3-point lift). For tractors equipped
with turf tires, also order wheel spacer kit 18240.**

29932

Rev. 8/10/2007

WOODS®
Tested. Proven. Unbeatable.

OPERATOR'S MANUAL

TO THE DEALER:

Assembly and proper installation of this product is the responsibility of the Woods® dealer. Read manual instructions and safety rules. Make sure all items on the Dealer's Pre-Delivery and Delivery Check Lists in the Operator's Manual are completed before releasing equipment to the owner.

The dealer must complete the Product Registration included with the Operator's Manual. The customer must sign the registration which certifies that all Dealer Check List items have been completed. The dealer is to return the prepaid postage portion to Woods, give one copy to the customer, and retain one copy. **Failure to complete and return this card does not diminish customer's warranty rights.**

TO THE OWNER:

Read this manual before operating your Woods equipment. The information presented will prepare you to do a better and safer job. Keep this manual handy for ready reference. Require all operators to read this manual carefully and become acquainted with all adjustment and operating procedures before attempting to operate. Replacement manuals can be obtained from your dealer. To locate your nearest dealer, check the Dealer Locator at www.WoodsEquipment.com, or in the United States and Canada call 1-800-319-6637.

The equipment you have purchased has been carefully engineered and manufactured to provide dependable and satisfactory use. Like all mechanical products, it will require cleaning and upkeep. Lubricate the unit as specified. Observe all safety information in this manual and safety decals on the equipment.

For service, your authorized Woods dealer has trained mechanics, genuine Woods service parts, and the necessary tools and equipment to handle all your needs.

Use only genuine Woods service parts. Substitute parts will void the warranty and may not meet standards required for safe and satisfactory operation. Record the model number and serial number of your equipment in the spaces provided:

Model: _____ **Date of Purchase:** _____

Serial Number: (see Safety Decal section for location) _____

Provide this information to your dealer to obtain correct repair parts.

Throughout this manual, the term **NOTICE** is used to indicate that failure to observe can cause damage to equipment. The terms **CAUTION**, **WARNING**, and **DANGER** are used in conjunction with the Safety-Alert Symbol (a triangle with an exclamation mark) to indicate the degree of hazard for items of personal safety.



This is the safety alert symbol. It is used to alert you to potential personal injury hazards. Obey all safety messages that follow this symbol to avoid possible injury or death.



Indicates a hazardous situation which, if not avoided, will result in death or serious injury.



Indicates a hazardous situation which, if not avoided, could result in death or serious injury.



Indicates a hazardous situation which, if not avoided, could result in minor or moderate injury.

IMPORTANT
or **NOTICE**

Is used to address practices not related to personal injury.

NOTE

Indicates helpful information.

WOODS®

ALITEC™
BMP®
CENTRAL FABRICATORS®
GANNON®
GILL®
WAIN-ROY®
WOODS®

2 Introduction

Gen'l (Rev. 7/20/2007)

TABLE OF CONTENTS

INTRODUCTION	2
GENERAL INFORMATION	3
SAFETY RULES	4
SAFETY DECALS	6
OPERATION	7
ASSEMBLY	10
PARTS LISTS	16
BOLT TORQUE CHART	23
BOLT SIZE CHART	24
PRODUCT WARRANTY	INSIDE BACK COVER
REPLACEMENT PARTS WARRANTY	BACK COVER

GENERAL INFORMATION

The purpose of this manual is to assist you in operating and maintaining your mower. Read it carefully. It furnishes information and instructions that will help you achieve years of dependable performance. These instructions have been compiled from extensive field experience and engineering data. Some information may be general in nature due to unknown and varying operating conditions. However, through experience and these instructions, you should be able to develop procedures suitable to your particular situation.

The illustrations and data used in this manual were current at the time of printing but, due to possible inline production changes, your mower may vary slightly in detail. We reserve the right to redesign and change the cutters as may be necessary without notification.

Throughout this manual, references are made to right and left directions. These are determined by standing behind the mower facing the direction of forward travel.



¡LEA EL INSTRUCTIVO!

Si no lee Ingles, pida ayuda a alguien que si lo lea para que le traduzca las medidas de seguridad.



This Operator's Manual should be regarded as part of the machine. Suppliers of both new and second-hand machines must make sure that this manual is provided with the machine.

SAFETY RULES



ATTENTION! BECOME ALERT! YOUR SAFETY IS INVOLVED!



Safety is a primary concern in the design and manufacture of our products. Unfortunately, our efforts to provide safe equipment can be wiped out by an operator's single careless act.

In addition to the design and configuration of equipment, hazard control and accident prevention are dependent upon the awareness, concern, judgement, and proper training of personnel involved in the operation, transport, maintenance, and storage of equipment.

It has been said, "The best safety device is an informed, careful operator." We ask you to be that kind of operator.

TRAINING

- **Safety instructions are important! Read all attachment and power unit manuals; follow all safety rules and safety decal information. (Replacement manuals and safety decals are available from your dealer. To locate your nearest dealer, check the Dealer Locator at www.WoodsEquipment.com, or in the United States and Canada call 1-800-319-6637.) Failure to follow instructions or safety rules can result in serious injury or death.**
- **If you do not understand any part of this manual and need assistance, see your dealer.**
- **Know your controls and how to stop engine and attachment quickly in an emergency.**
- **Operators must be instructed in and be capable of the safe operation of the equipment, its attachments, and all controls. Do not allow anyone to operate this equipment without proper instructions.**
- **Never allow children or untrained persons to operate equipment.**

PREPARATION

- **Check that all hardware is properly installed. Always tighten to torque chart specifications unless instructed otherwise in this manual.**
- **Always wear relatively tight and belted clothing to avoid getting caught in moving parts. Wear sturdy, rough-soled work shoes and protective equipment for eyes, hair, hands, hearing, and head; and respirator or filter mask where appropriate.**
- **Make sure attachment is properly secured, adjusted, and in good operating condition.**
- **Remove accumulated debris from this equipment, power unit, and engine to avoid fire hazard.**

- **Make sure all safety decals are installed. Replace if damaged. (See Safety Decals section for location.)**

- **Make sure shields and guards are properly installed and in good condition. Replace if damaged.**

- **Inspect and clear area of stones, branches, or other hard objects that might be thrown, causing injury or damage.**

OPERATION

- **You may not be able to stop the tractor safely if the clutch or brake pedal mechanisms are improperly adjusted, allowing them to contact mower components.**

- **When the mower lift stops are installed as instructed in this manual, properly adjusted clutch and brake pedal mechanisms will not contact mower components. You should frequently check that the tractor clutch and brake pedal mechanisms are in adjustment.**

- **If the clutch or brake pedal mechanisms can contact mower components, do not put mower into service until properly adjusted.**

- **Do not put mower into service unless discharge chute is installed and in good condition. Replace if damaged.**

- **Keep bystanders away from equipment.**

- **Do not operate or transport equipment while under the influence of alcohol or drugs.**

- **Never direct discharge toward people, animals, or property.**

- **Operate only in daylight or good artificial light.**

- **Keep hands, feet, hair, and clothing away from equipment while engine is running. Stay clear of all moving parts.**

- **Always comply with all state and local lighting and marking requirements.**

- **Never allow riders on power unit or attachment.**

- **Always sit in power unit seat when operating controls or starting engine. Place transmission in neutral, engage brake, and ensure all other controls are disengaged before starting power unit engine.**

- **Look down and to the rear and make sure area is clear before operating in reverse.**

- **Do not operate or transport on steep slopes.**



SAFETY RULES

ATTENTION! BECOME ALERT! YOUR SAFETY IS INVOLVED!



- Do not stop, start, or change directions suddenly on slopes.
- Use extreme care and reduce ground speed on slopes and rough terrain.
- Watch for hidden hazards on the terrain during operation.
- Stop power unit and equipment immediately upon striking an obstruction. Turn off engine, remove key, inspect, and repair any damage before resuming operation.

TRANSPORTATION

- Always comply with all state and local lighting and marking requirements.
- Never allow riders on power unit or attachment.
- Do not operate PTO during transport.
- Watch for hidden hazards on the terrain.
- Do not operate or transport on steep slopes.
- Do not operate auxiliary hydraulics during transport.
- Do not operate or transport equipment while under the influence of alcohol or drugs.

MAINTENANCE

- Before dismounting power unit or performing any service or maintenance, follow these steps: disengage power to equipment, lower the 3-point hitch and all raised components to the ground, operate valve levers to release any hydraulic pressure, set parking brake, stop engine, remove key, and unfasten seat belt.
- Do not modify or alter or permit anyone else to modify or alter the equipment or any of its components in any way.
- Always wear relatively tight and belted clothing to avoid getting caught in moving parts. Wear sturdy, rough-soled work shoes and protective equipment for eyes, hair, hands, hearing, and head; and respirator or filter mask where appropriate.
- Never go underneath equipment (lowered to the ground or raised) unless it is properly blocked and secured. Never place any part of the body under-

neath equipment or between moveable parts even when the engine has been turned off. Hydraulic system leak down, hydraulic system failures, mechanical failures, or movement of control levers can cause equipment to drop or rotate unexpectedly and cause severe injury or death. Follow Operator's Manual instructions for working underneath and blocking requirements or have work done by a qualified dealer.

- Make sure attachment is properly secured, adjusted, and in good operating condition.
- Keep all persons away from operator control area while performing adjustments, service, or maintenance.
- Make certain all movement of equipment components has stopped before approaching for service.
- Frequently check blades. They should be sharp, free of nicks and cracks, and securely fastened.
- Do not handle blades with bare hands. Careless or improper handling may result in serious injury.
- Your dealer can supply genuine replacement blades. Substitute blades may not meet original equipment specifications and may be dangerous.
- Tighten all bolts, nuts, and screws to torque chart specifications. Check that all cotter pins are installed securely to ensure equipment is in a safe condition before putting unit into service.
- Make sure all safety decals are installed. Replace if damaged. (See Safety Decals section for location.)
- Make sure shields and guards are properly installed and in good condition. Replace if damaged.
- Wear gloves when installing belt. Be careful to prevent fingers from being caught between belt and pulley.

STORAGE

- Block equipment securely for storage.
- Keep children and bystanders away from storage area.



SAFETY & INSTRUCTIONAL DECALS



ATTENTION! BECOME ALERT! YOUR SAFETY IS INVOLVED!
Replace Immediately If Damaged!

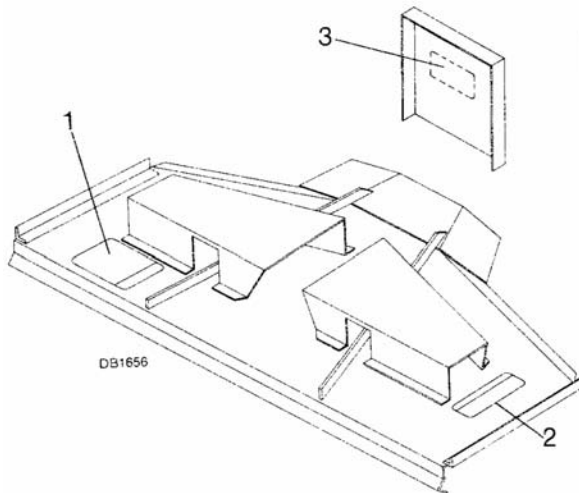

1 - 25505



WARNING

TO AVOID SERIOUS INJURY OR DEATH,

- Read Operator's Manual and follow all safety precautions. (Contact dealer for manuals.)
- Keep shields and guards in place. Keep clear of drives and belts.
- Lower implement, stop engine and remove key before dismounting.
- Block up implement and remove key before working underneath.
- Do not operate mower in vicinity of other persons. Never allow riders.
- Know how to stop tractor and equipment quickly in an emergency.
- Clear mowing area of debris.
- Never allow children or unqualified persons to operate equipment.
- Be careful on uneven terrain. Decrease speed when turning.
- Do not operate in transport position.

25505-G



3 - SERIAL NUMBER PLATE

BE CAREFUL!

Use a clean, damp cloth to clean safety decals.

Avoid spraying too close to decals when using a pressure washer; high-pressure water can enter through very small scratches or under edges of decals causing them to peel or come off.

Replacement safety decals can be ordered free from your Woods dealer. To locate your nearest dealer, check the Dealer Locator at www.WoodsEquipment.com, or in the United States and Canada call 1-800-319-6637.

2 - 53425



DANGER



ROTATING BLADES AND THROWN OBJECTS

- Do not put hands or feet under or into mower when engine is running.
- Before mowing, clear area of objects that may be thrown by blade.
- Keep bystanders away.
- Keep discharge chute and guards in place and in good condition.

BLADE CONTACT OR THROWN OBJECTS CAN CAUSE SERIOUS INJURY OR DEATH.

53425-B

OPERATION

WARNING

- Do not allow children or unqualified persons to operate equipment.
- Keep bystanders away from equipment while it is in operation.

CAUTION

- Stop mower and tractor immediately upon striking an obstruction. Turn off engine, remove key, inspect and repair any damage before resuming operation.
- Always wear relatively tight and belted clothing to avoid entanglement in moving parts. Wear sturdy, rough-soled work shoes and protective equipment for eyes, hands, hearing and head.

MOWING GRASS

Woods model **59** and **L59** series mowers are equipped with suction-type blades which make them ideal for finish mowing large areas of lawn. The machine should be run level when mowing, and the uncut area should be kept to the left side (right side on left-handed machine). This prevents a small windrow that might otherwise occur.

Streaking

With certain types of grass and under certain seasonal conditions, the front caster wheels may roll the grass down enough that it will not come all the way back up and will not be cut as short as the surrounding area. This may appear to be a streak left by the spindle, but it is not. The only solution, under these conditions, is to carry the weight of the machine on the lift chains with the caster wheels adjusted up so they carry the weight when riding a high ridge or high spot.

TRACTOR OPERATING INSTRUCTIONS

Operate the tractor at full governed rpm when doing normal mowing. If the forward speed is too high, a lower gear can be used.

Height Adjustment (Without Casters)

The mower is raised or lowered and the mowing height is maintained by the tractor hydraulic system.

Set the hydraulic control lever stop for the desired mowing level. Adjust the side skids so that they just

clear the ground. The side skids will minimize scalping by lifting the mower over bumps.

Height Adjustment (With Casters)

Adjustment for **59** and **L59** casters is made by placing axle in upper and lower holes in the yoke, or by moving spacers on top or bottom of the pivot shaft. Raise mower off the ground when backing and turning at the same time.

Mower Attitude

Position front of mower level with or slightly below the rear to provide closer cutting. Mowing with the front end higher will produce ragged cuts with a scalloped look, excessive shredding, and will require extra power.

Attitude Adjustment (Figure 1)

For best mowing results, dimension "A" should not be more than 1/2" higher, and never lower, than dimension "B".

Dimension "B" is set by adjusting casters, gauge wheels or lift chains.

Dimension "A" is set by raising or lowering push channel arms in idler bracket.

NOTICE

- Any adjustment to either dimension "A" or "B" will require adjustment to the other.

Check cutting height and attitude by placing a straight edge along the outside edge of the mower frame as shown in Figure 1.

Measure from the bottom edge of the straight edge at the front and rear at least 32" apart. The front measurement should be approximately 1/2" lower than the rear.

To determine cutting height, it is necessary to subtract the distance the blade is below mower frame from the front measurement. On **L59**, the blade is 4-5/8" below the mower frame.

When checking cutting height, be sure to take measurements on both sides of the mower. Be sure the mower is level from side to side using these measurements.

When changes are made to cutting height or attitude, be sure to check belt alignment and tension.

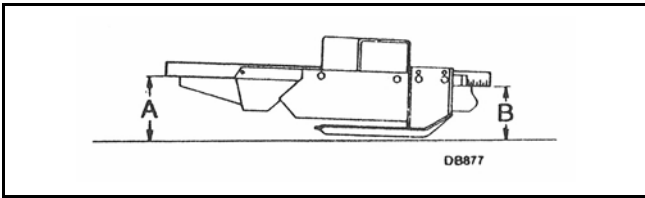

Figure 1. Attitude Adjustment

NOTICE

- Improper belt alignment or tension can cause premature belt failure.

Lubrication

Grease caster pivot and wheel every 8 hours of operation.

There are grease fittings on each of the three blade spindles, which are accessible without shield removal. Grease every 24 hours of operation with a good grade light to medium grease gun.

NOTICE

- Do not over grease spindles. Excess grease could be transferred to the belt and cause slippage or premature failure.

Belt Tension (Figure 2)

Set belt tension using a spring scale or other force measuring device. Remove left belt shield. Attach scale between center and left pulley. Apply between 3 and 4 pounds of force. Belt deflection should measure 5/16" for normal conditions.

Tension may be increased if necessary to prevent belt from slipping in heavy mowing conditions. When checking tension without a force measuring device, the belt, when properly set, should feel very tight.

Cycle belt through at least two revolutions after any adjustment before checking tension. These belts are very strong and need to be adjusted very tight. Belts are more likely to be damaged by excessive slippage than from being overtightened.

NOTICE

- Belt must not rub deck or crosswise support.

Tension adjustments may be made by moving the idler pulleys up or down.

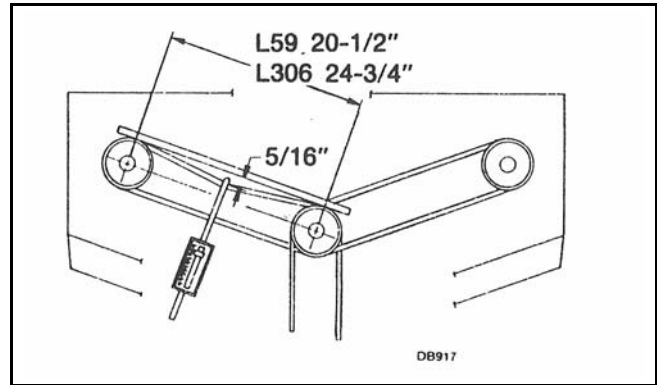

Figure 2. Proper Belt Tension

NOTICE

- Alignment must be rechecked if it is necessary to move idler pulleys to get proper belt tension.
- Tension on a new belt should be readjusted every half hour for the first two hours and then checked every 8 hours of operation.

Side Shield & Discharge Chute

Side shield and discharge chute are provided for discharge end of mower (left end on white frames and right end on yellow frames). Use side shield for normal mowing and in areas where other persons may be present. Use discharge chute for very heavy mowing conditions.

NOTICE

- Always use either side shield or discharge chute.

Optional Equipment

Optional equipment available for this equipment includes casters for cutting height control, front roller to minimize scalping, low and extra suction blades, and a leaf mulcher. Low suction blades are for sandy areas where abrasive action could cause excessive blade wear. Extra suction blades are designed to lift up fragile downed grasses for better cutting results and are also recommended for use with leaf mulcher attachments.

Mower Spindle Assemblies

Mower spindle assemblies are equipped with two tapered roller bearings. Bearing adjustment is held by a roll pin. Adjustment should not be necessary. Repair requires special skills and tools. You may save time and money by using a new spindle assembly.

Blade Servicing

Keep blades sharp for a good mowing job. Sharpen both ends of the blade the same amount to maintain balance. Do not sharpen blade to a razor edge, but leave a 1/16" blunt edge. Do not sharpen back side of blade. When replacing blades, do not substitute any bolt for the special Nylok blade bolt. The Nylok bolt is self-locking, meeting the non-loosening requirements for this application.

NOTICE

■ On mowers with white frames, the blade bolts have left hand threads.

59 mowers use cup washers under blades. These washers will burn and lose their clamping force if excess slippage occurs. Inspect and replace as necessary.

HOW TO SOLVE BELT PROBLEMS

Assemble as shown on mower decal. If not installed correctly, more twist will result than is allowable.

Belt whip is caused by belt misalignment unless mower is driven by a rough-running or 2-cylinder engine.

Proper position: Adjust mower forward and back to such a position that the rear take-up idlers are near the bottom of their slots when the belt lines up with the proper groove in the center pulley and is tight. Never run the idlers high in the slots as this will cause misalignment.

It is assumed that the mower is adjusted to run approximately level. If the front of the mower is down, the idlers will have to be raised. If the back of the mower is down, the idlers will have to be down further. Belts must be in proper alignment with sheave grooves as shown in Figure 4.

PTO pulleys must be moved in or out to cause the belt to be in alignment with the idlers.

Belt Tension: Run belts very tight. Present belt designs are much stronger than we are accustomed to and will stand more tension. Slipping will heat and ruin a belt but tension is not harmful. You can minimize the amount of change in belt length as mower is raised and lowered by keeping the rear idlers adjusted to a low position.

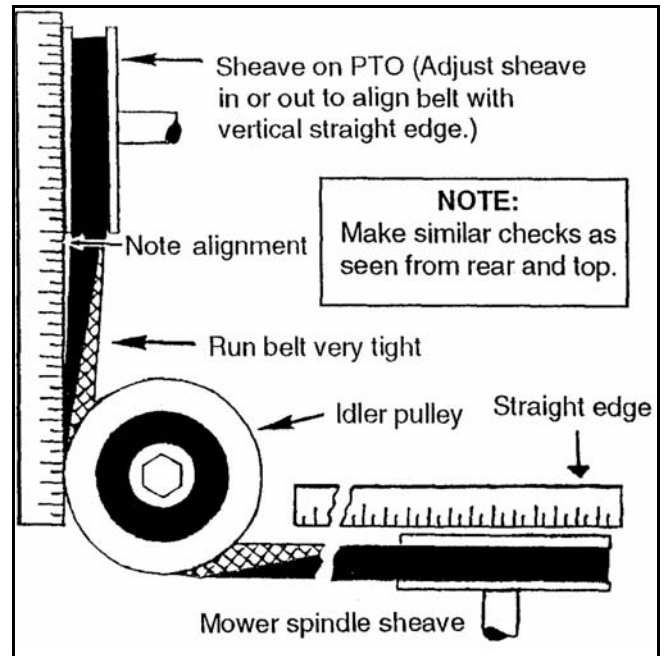

Figure 3. Use of Straight Edge (Side View)

How to Align a Twisted Belt

Right: Inside edge of belt are approximately lined up with the sheave.

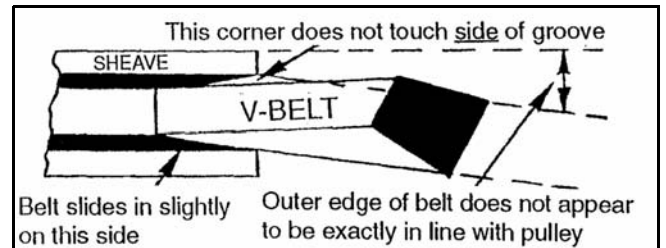

Figure 4.

Wrong: Outer edge of belt appears to be in line.

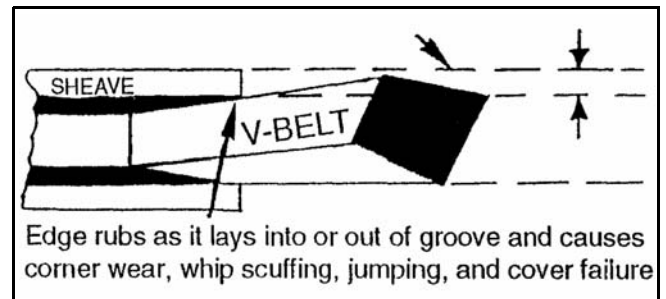

Figure 5.

ASSEMBLY

MOWER FRAME ASSEMBLY

Open box and lay parts out in an orderly manner.

Side Shield (See page 20)

Attach side shields (2 and 3) to mower with 3/8 x 1" bolts and flange nuts. A side discharge chute (5) may be installed on discharge end of mower in place of that side shield.

Center Shield (See page 20)

To allow more lift on tractors with minimum ground clearance, such as Fords, IH LoBoy, Kubotas, Satohs, etc., a center belt shield is not offered. If the box of parts has a center belt shield, bolt center belt shield bracket (34) to deck with 3/8 x 1" bolt. Bolt center shield (10) to bolts welded in deck and bracket (34).

Side Skids

Bolt skids using 3/8 x 1" heat-treated bolts (torque to 35 lbs-ft), lock washer, and nuts in such a position that they will be carried close to the ground, but so they **do not ride continually on the ground when mower is operated at desired mowing height.**

Front Toe Guards (See page 20)

Front toe guards (6) are furnished for some mowers. When provided, bolt them to the front of the mower, using 3/8 NC x 3/4" carriage bolt and 3/8" flange lock nuts. (**NOTE:** On **59** & **L59** where casters are installed on outer deck rails, bolt toe guards to mower so outer ends are about 2" in from end of deck. Otherwise, end of toe guard will be about 1/2" in from end of deck.)

Crosswise Rear Support (See page 20)

Install bushing (16) into center hole in crosswise rear support and bolt it to back of mower deck with short bar forward and offset up using 1/2 x 2" hex head cap screw and 1/2" flange lock nut.

NOTE: On **L59**, **L306F10-2**, "**S**", **JD85**, **JD95** & **GM4** mountings, a special crosswise rear support is provided. If tractor is equipped with turf tires, use upper center hole in crosswise support, and for Ag tires, use lower hole.

Channel Arms (See page 20)

Slide mower under tractor. Attach channel arms (12) to mower frame using 5/8 x 1-1/2" clevis pin and safety pins. Pin crosswise rear support bar (15) between channel arms and bolt center to frame angle bracket as shown in the main assembly drawing.

Casters

If casters are used, see page 19, except for the L59 mower on Ford 1000, 1600, 1700, 1900, and Satoh S650. (See mounting frame drawing in manual.)

Front Roller

Put front roller bracket (28) on left side and front roller bracket (27) on right side of mower using 3/8" carriage bolts and nuts. This will put the highest hole in brackets rearward.

Assemble roller and roller rod (26) in rear holes in brackets (27 & 28). Secure with 3/16" cotter pins. Turn roller by hand to see that it turns freely.

MOUNTING FRAME ASSEMBLY (SEE PAGE 16)

Idler & Mounting Bracket Assembly

Remove drawbar from tractor and bolt idler bracket (4) between wheel housings, using holes where drawbar was attached. Secure with 5/8 x 1-1/4 bolts and lock washers.

NOTE: If tractor is equipped with 13.6 - 16 turf tires, the wheel spacer kit (16) (optional) must be used. Use one spacer between each wheel and axle flange.

NOTE: If tractor is equipped with 3-point lift, remove outer bars holding lower arm in place and bolt idler bracket to tractor. See Figure 9 for further instructions.

Idler Assembly to Idler Bracket

Install one V-groove idler (8) on the outside of left vertical slot of idler bracket (4) and one to inside of right vertical slot. Use three 5/8" flat washers between idlers and idler bracket. Bolt together using 5/8 x 2-1/2 carriage bolts, lock washers, and nuts.

Drive Pulley

Remove PTO shield on back of tractor. Install bushing (12) into 6-1/2" pulley (11) and install assembly onto PTO shaft. Adjust drive sheave (11) fore and aft for proper alignment after belt is installed. Torque bolts to 12 lbs-ft alternating back and forth on each bolt at least six times.

Belt Assembly and Adjustment

Slide mower under tractor.

NOTE: It may be necessary to remove one of the channel arms attached to mower deck.

After mower is centered under tractor, reinstall push channel and pin push channels to idler and mounting frame using 5/8 x 1-3/4 clevis pin.

First put belt on the bottom groove, right hand side of the center sheave. Then thread it to left, around the left hand sheave.

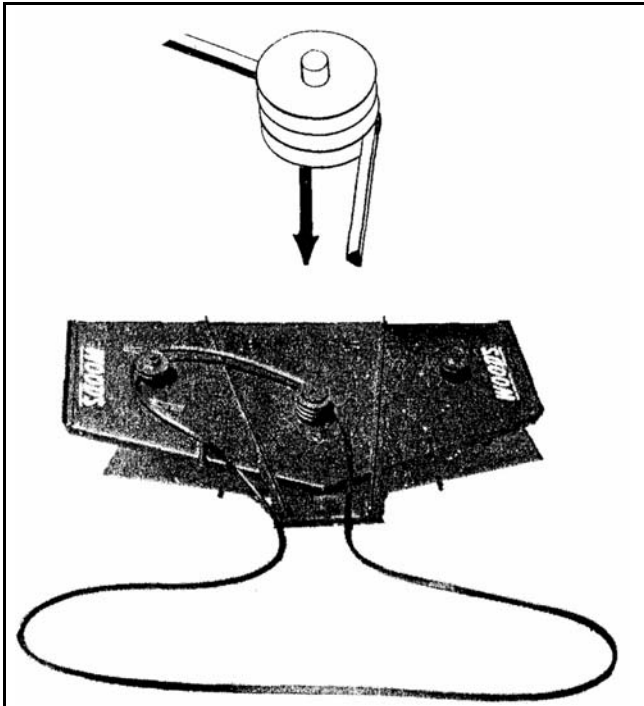

Figure 6.

Bring the belt back across the center sheave in the center groove over to the right outside sheave.

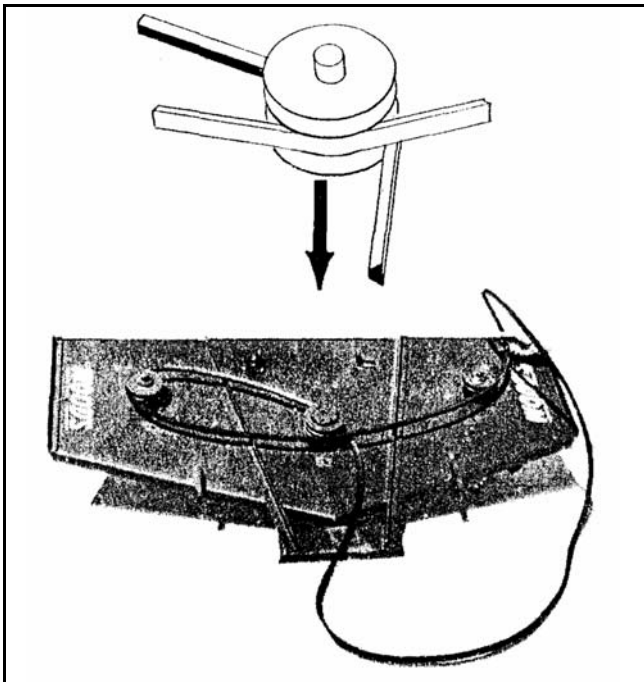

Figure 7.

Then thread it back across the front of the center sheave in the top groove.

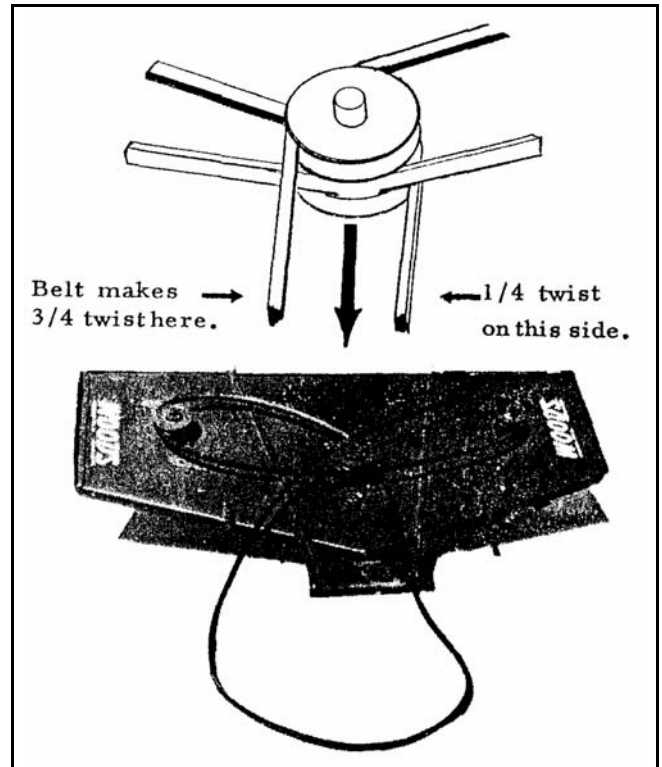

Figure 8.

Proper Twist: The belt then follows with a 3/4 twist back under the left V-idler, up over the drive sheave and back down under the right idler pulley. This will leave a 1/4 twist in the section of belt extending from the right V-idler to lower groove of the center mower sheave.

Adjust the mower to proper cutting height. The front of the mower should be slightly lower than the rear of the best cutting and least power requirement.

Idler Adjustment: Make minor belt adjustment with idlers but keep left idler about 1" above being in line with the groove in which the belt runs on the center sheave of the mower and right idler about 1" below. Move mower fore and aft for major adjustments. On L306K210, K260, S, and F10, use belt takeup idlers on mower deck for major adjustment.

Make major adjustments by sliding mower fore and aft, using six holes in channel arms as required. Using a new belt, the push arms normally will be attached to the idler frame with mower sitting in second hole from front end of channels.

Minor adjustments are made up and down with idler pulleys. After belt has been run for 15 to 20 minutes, belts should be re-tightened. **Run very tight.**

Lift Assembly

If casters are used, they should be installed now, but leave out front bolt in caster arm. Using a 3/8 x 1-1/2 bolt and flat washer, attach one end of chain through

front hole of caster and deck rail; and secure with 3/8" lock washer and nut. In some cases it is necessary to open up the end link of the chain slightly so a 3/8" bolt will pass through it.

On **IH184**, install 1/2 x 5/8 x 7/16 bushing (39) in tractor rockshaft arm. Install 1/2" flat washer on each side of arm and install 1/2 NC x 1-3/4 hex head cap screw. Install 1/2 x 5/8 x 5/16 sleeve (3) in lift lug (2) and bolt it to inside of rockshaft arm.

On **IH154 & IH185** attach lift angle (2) to outside of tractor rockshaft using 1/2 x 1-3/4 bolt and 1/2 x 5/8 x 5/16 sleeve and 1/2" flange lock nut.

Screw 3/8" nut onto the 3/8" eye bolt (26) and slide eye bolt up through bottom of lift lug (2). Secure with another 3/8" nut. Repeat instructions for opposite side of tractor.

Hook upper end of chain (1) into eye bolt (26), adjusting chains and eye bolts to carry mower level. Raise mower slowly checking that mower does not hit tires, bottom of tractor, or tie rod when lift is fully raised. Remove center belt shield from mower deck. Cut off excess chain after proper adjustment has been made.

Belt Shield

Attach belt shield (13) to rear of tractor over drive sheave by installing 5/16 x 3/4 flange head bolt into tapped holes on rear of tractor.

Casters (Optional) (See page 19)

Assemble casters to deck rails with offset inward. **Caution must be taken when turning and backing up that caster wheels do not lock up with front tractor tires.**

Leaf Mulcher (Optional) (See page 22)

1. Turn mower upside down on saw horses. If mower has a bolt-on front shield, adjust shield all the way down in long slots. Remove side shields. Leave side skids on. If optional front roller has been installed, it must be removed.
2. On mowers with bent-down front frame, remove center baffle and drill two 7/16 diameter holes in front of mower at the dimensions shown in parts drawing.
3. Attach slotted angles (2) to leaf mulcher.
4. Place leaf mulcher over blades on mower. Attach angles (2) and mower side shields to side frame angle on mower. All 59 mowers with bolt-on front shield will use front shield hole to attach angles (2). Bolt side shields to mower using 3/8 flat washers for spacers.
5. On mowers with bolt-on front shield, bolt front of leaf mulcher to bottom of slots in front shield with 3/8 x 1" bolts and flat washers. On mowers with bent-down front frame, bolt leaf mulcher to inside of mower in holes drilled in front frame using 3/8 x 1-1/2" bolts and 5/8 long pipe spacers between leaf mulcher and mower. On some mowers where 5/8" pipe may be too long, substitute 3/8 flat washers.
6. Drill 7/16 holes in rear of mower deck through holes in leaf mulcher rear plates and bolt rear of leaf mulcher to deck using 3/8 x 1" bolts.
7. Tighten all bolts securely. Turn each blade individually inside the leaf mulcher to see that it clears the leaf mulcher rings. If necessary, the rings may be re-shaped with a hammer to clear the leaf mulcher rings.

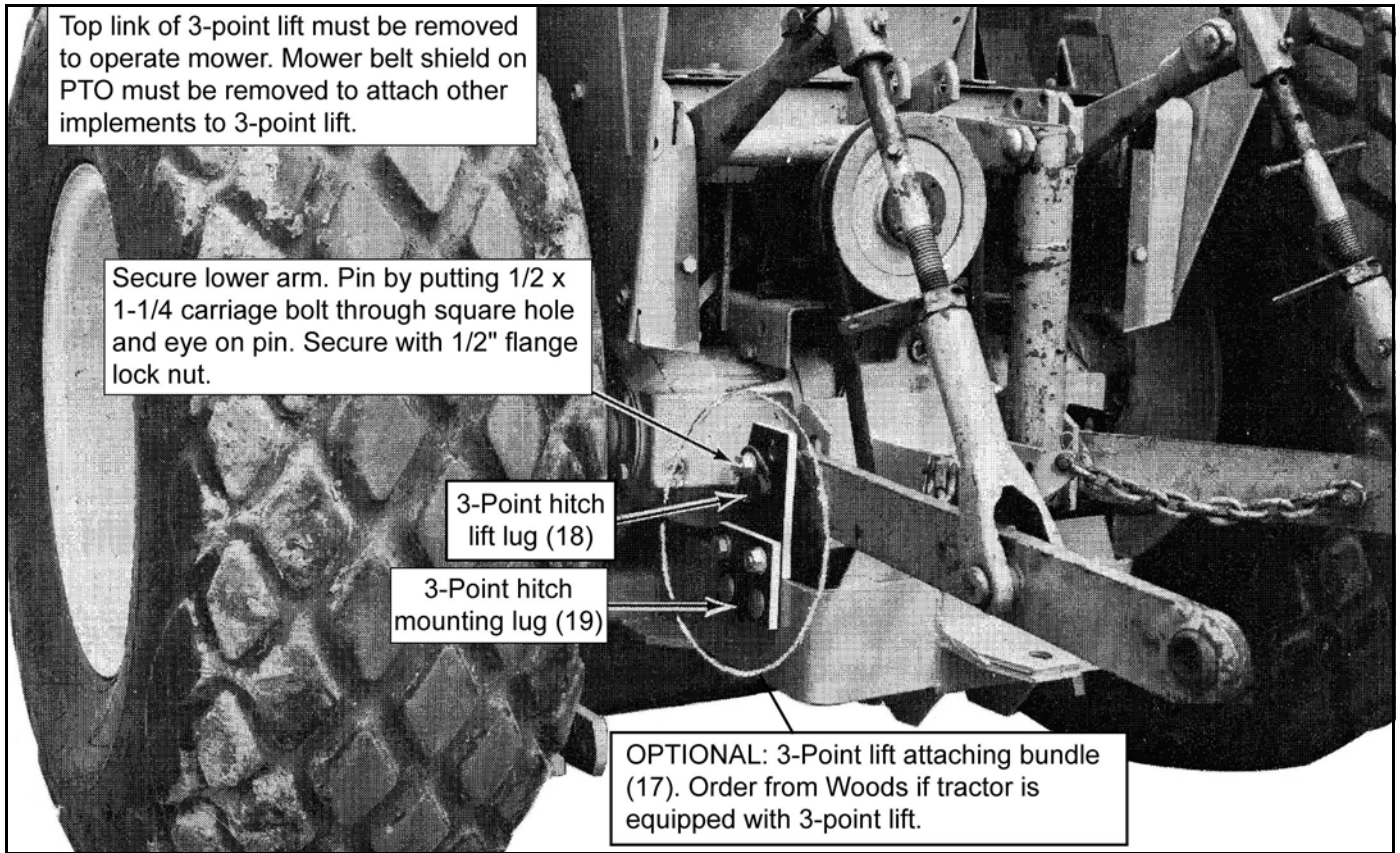

Figure 9. Mounting Frame Shown with 3-Point Lift Mounting Kit & 3-Point Lift Installed

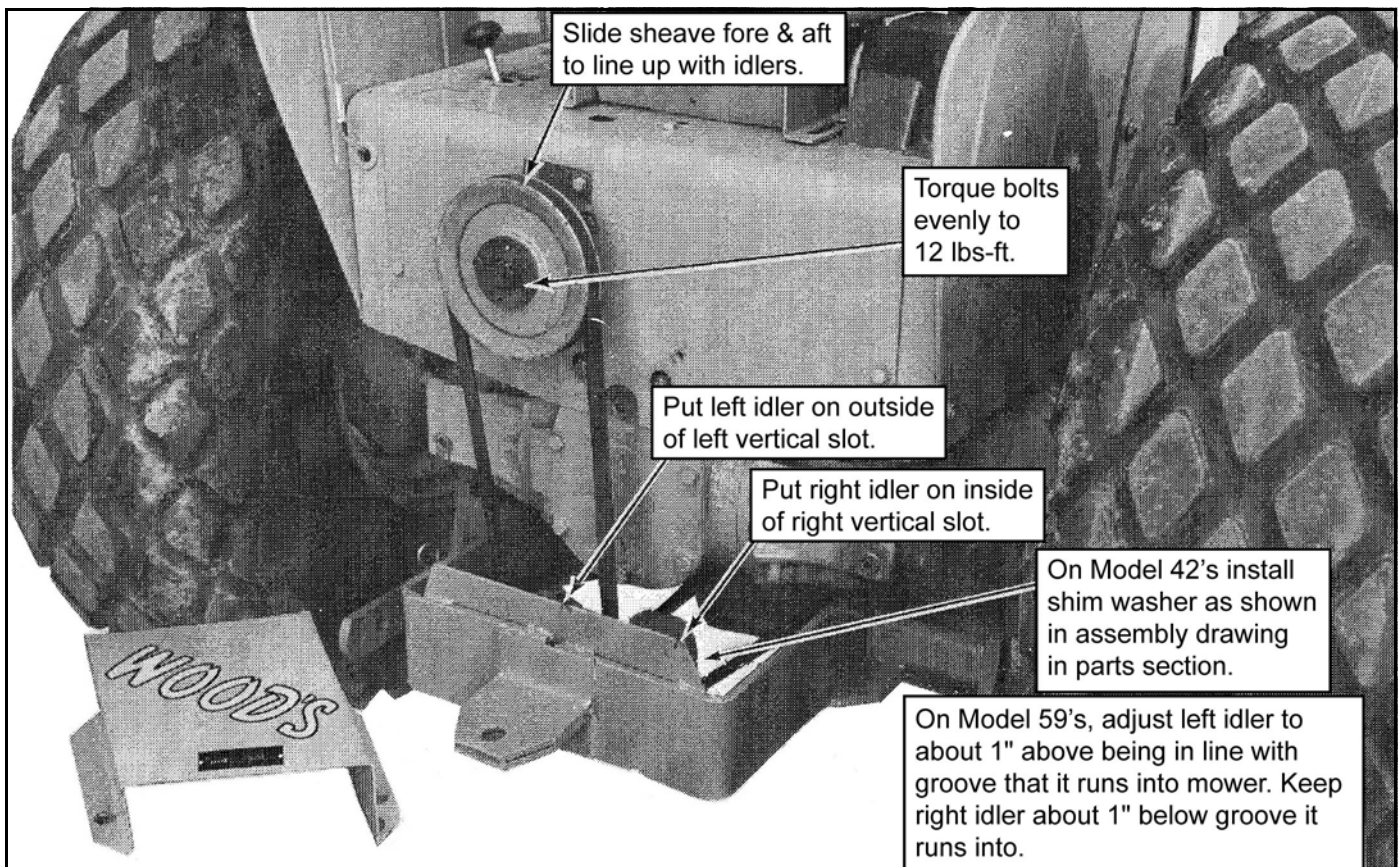

Figure 10. Mounting Frame Assembly

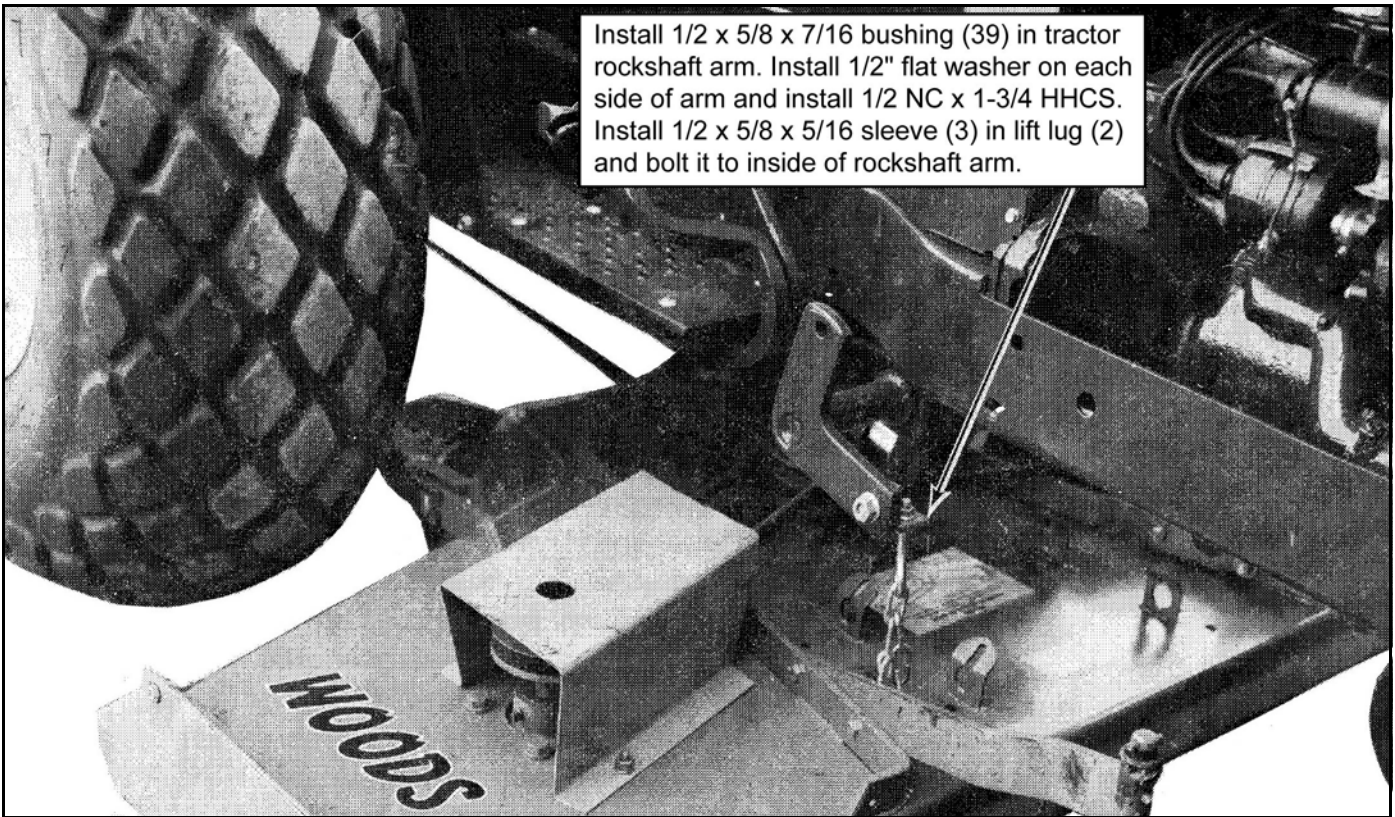

Figure 11. Lift Assembly

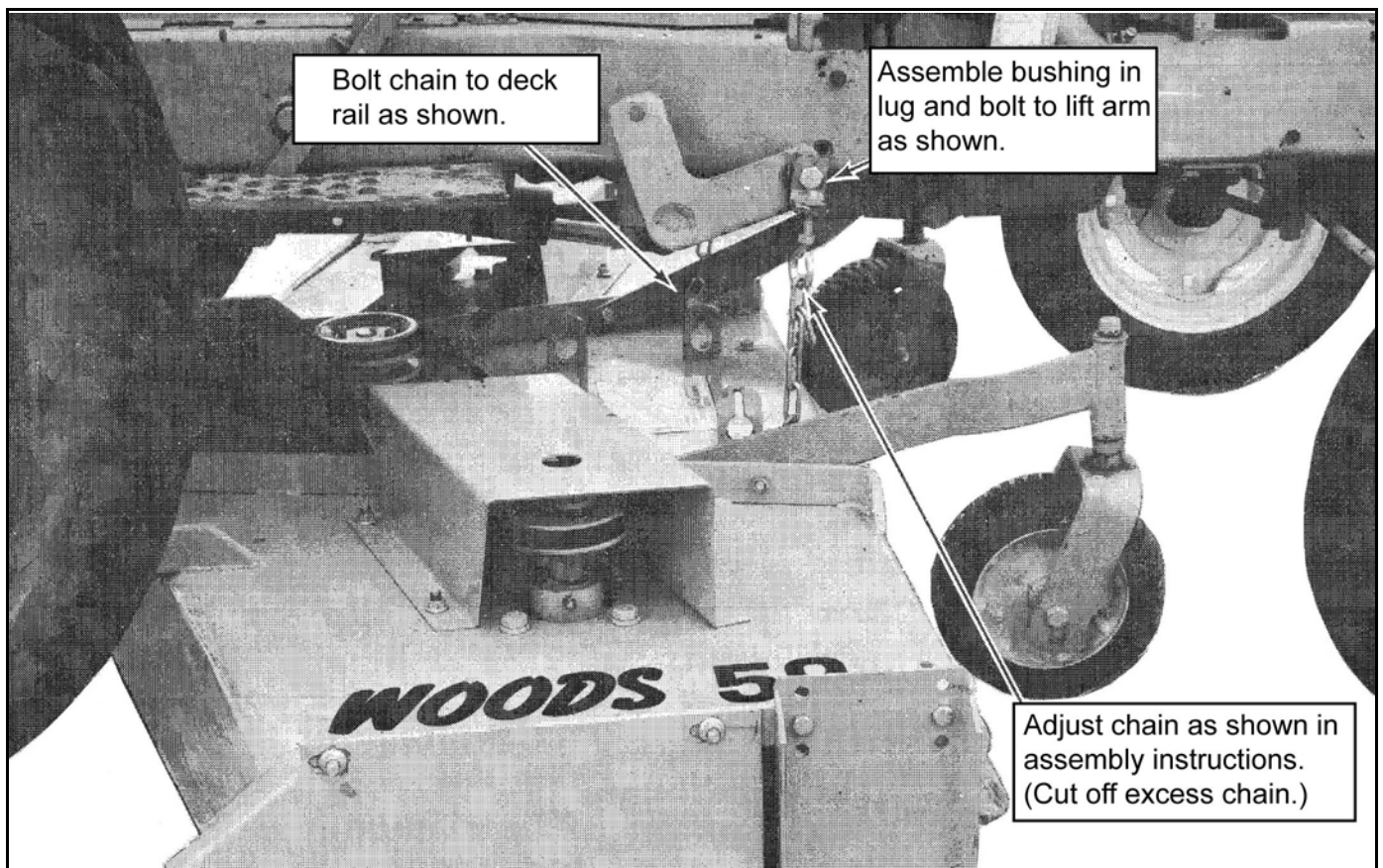
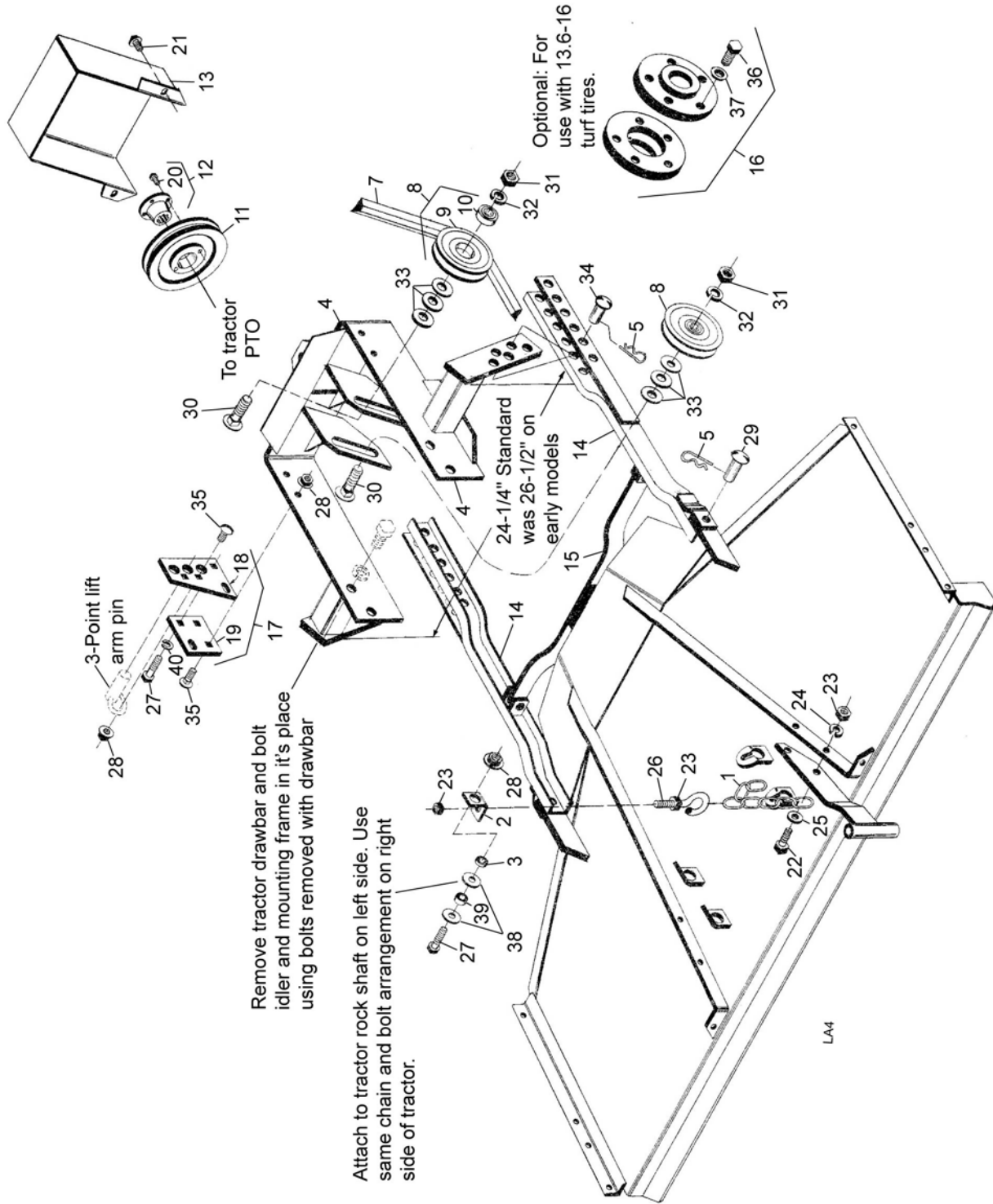

Figure 12. Lift Assembly

NOTES

MOUNTING FRAME ASSEMBLY



MOUNTING FRAME ASSEMBLY

REF	PART	QTY	DESCRIPTION	REF	PART	QTY	DESCRIPTION	
1	6911	2	Chain (7 link)	21	71851 *		5/16 NC x 3/4 Flange head bolt GR5	
2	10772	2	Lift angle	22	976 *		3/8 NC x 1-1/2 Hex head cap screw GR5	
3	18314	2	1/2 x 5/8 x 5/16 Sleeve	23	835 *		3/8 NC Hex nut	
4	9814 †	1	Idler and mounting frame assembly (standard)	24	838 *		3/8 Lock washer	
5	2688	6	5/32 Cotter pin	25	565 *		3/8 Flat washer	
7	18440	1	Belt (special W180)	26	5762		3/8 NC Eye bolt	
8	4336	2	Idler sheave with bearing	27	24576 *		1/2 NC x 1-3/4 Hex head cap screw GR5	
9	4335	2	Idler sheave without bearing	28	11900 *		1/2 NC Flange lock nut	
10	6095	2	Bearing (for ref 8)	29	4097		5/8 x 1-1/2 Clevis pin	
11	3493	1	Drive sheave 6.1 PD	30	5836 *		5/8 NC x 2-1/2 Carriage bolt GR5	
12	1506	1	Spindled bushing with bolts	31	230 *		5/8 NC Hex nut	
13	18310	1	Drive shield	32	1286 *		5/8 Lock washer	
14	18241	2	Channel arms (standard) -or-	33	692 *		5/8 Flat washer	
14	13314	2	Channel arms (use when idler bracket measures 26-1/2" between vertical push bars)	34	410		5/8 x 1-3/4 Clevis pin	
15	18245	1	Crosswise rear support (standard) -or-	35	2615 *		1/2 NC x 1-1/4 Carriage bolt GR5	
15	3485	1	Crosswise rear support (use when idler bracket measures 26-1/2" between vertical push bars)	36	18250		1/2 NF x 1-1/2 HHCS, GR5 (order with item 37)	
16	18240	1	Rear wheel spacer kit (optional) (use with 13.6 - 16 turf tires)	37	23389		Wheel spacer bolt sleeve (order with item 36)	
17	27207	1	3-Point hitch bracket kit (optional) (includes two ref 18 and ref 19, and necessary hardware)	38	854 *		1/2 Flat washer	
18	18371	2	3-Point hitch lift lug	39	24667		1/2 x 5/8 x 7/16 Bushing	
19	27208	2	3-Point hitch mounting bracket	40	855 *		1/2 Lock washer	
HARDWARE								
20	2457 *		1/4 NC x 3/4 Hex head cap screw GR5					* Standard hardware, obtain locally
								† On early models where push arms measure 26-1/2" between them, also order two #18241, one #18245, and two #8098.

SPINDLE ASSEMBLY

REF	PART	QTY	DESCRIPTION
1	4116	1	Spindle
2	5089	2	Seal
3	4114	1	Sleeve
4	4115	1	Pin
5	4107	2	Bearing cone
6	4117	1	Housing with cups
7	4106	2	Bearing cup
8	1972 *	1	Grease fitting
9	4105	1	Spindle shaft
10	4110	1	Shoulder washer
11	6950KT	1	20-1/4 Medium suction blade (std for 59) -or-
11	26559KT †	1	20-1/4 Low suction blade (optional for 59)
12	10658	1	5/8 NC x 1-1/2 Nylok bolt
13	3490	1	Blade bolt wrench (used prior to 1964)
14	2974	1	Spindle lock wrench
16	10635	2	5/8 Cup washer
17	692 *	1	5/8 Flat washer
18	1015825	1	Blade bolt & washers (complete)

* Obtain locally, standard hardware

† For use in sandy areas or where high abrasive wear occurs on fin of standard blade.

NOTE: Repair items shaft (9) and sleeve (3) do not have a hole drilled in them for pin (4). After new parts have been assembled and proper bearing adjustment obtained, drill a 3/16 diameter hole through sleeve and shaft. Drive in Sel-lock pin to hold proper bearing adjustment.

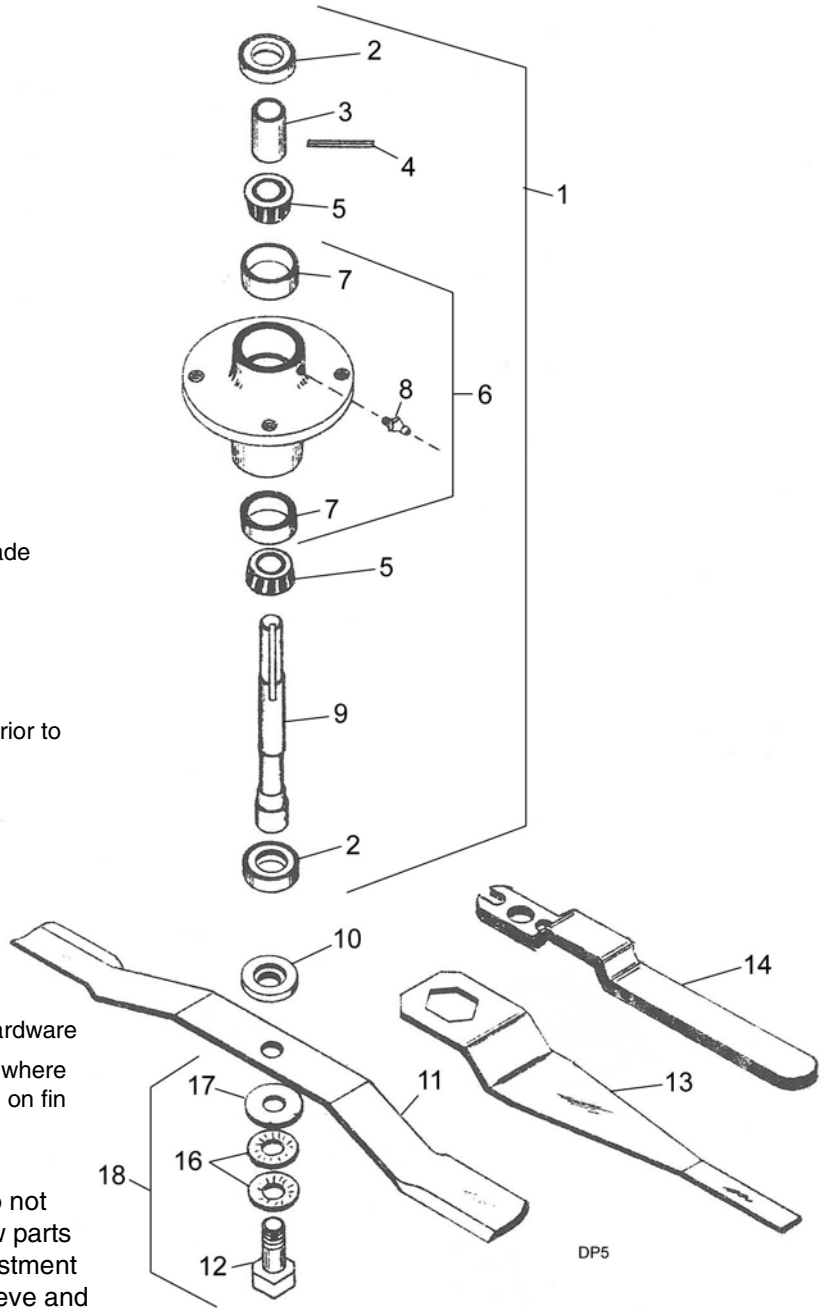

CASTERS

REF	PART	QTY	DESCRIPTION
1	29750	1	Right and left caster bundle
2	12243	1	Caster yoke (includes bolt, nut & sleeve)
3	29746 (a)	1	Right caster arm asy, 13-5/32" long -or-
3	6761 (a)	1	Right caster arm asy, 16-5/32" long
4	29747 (a)	1	Left caster arm asy, 13-5/32" long -or-
4	18424 (a)	1	Left caster arm asy, 16-5/32" long
5	19703	1	8" HD Caster wheel with sleeve
7	-----	*	1 Straight 1/4 self-tapping grease fitting (for steel wheel) -or-
7	195	*	1 Straight 1/8P thread grease fitting (for polyethylene wheel)
8	21020	1	1/4 x 1-1/4 Spirol pin -or-
8	1285	*	1 1/4 x 1-1/2 Cotter pin
9	12296	*	1 1/4 - 28 Straight grease fitting, 15/32" long
10	12169	*	2 3/8 NC x 1-1/4 HHCS GR5
11	838	*	2 3/8 Standard lock washer
12	835	*	2 3/8 NC Hex nut, plated
13	765	*	1 1/2 NC Hex lock nut
14	23479	1	1/2 NC x 5 HHCS GR5
15	29368 (c)	1	1/2 x 3/4 OD x 3-3/8 Sleeve -or-
15	12242 (c)	1	17 GA Wall x 5/8 OD x 3-3/8 tube
16	29375 (b)	2	3/4 Bore flanged bearing for 1-1/8 hole -or-
16	4228 (b)	2	5/8 Bore flanged bearing for 1-3/8 hole -or-
16	2905 (b)	2	5/8 Bore flanged bearing for 1-1/8 hole -or-
16	65578 (b)	2	3/4 Bore x 1.385 flanged wheel bearing with groove
17	22240	2	3/4 x 1-3/16 x 10 GA Washer
18	4181	2	25/32 x 1 x 1/2 Heat-treated sleeve

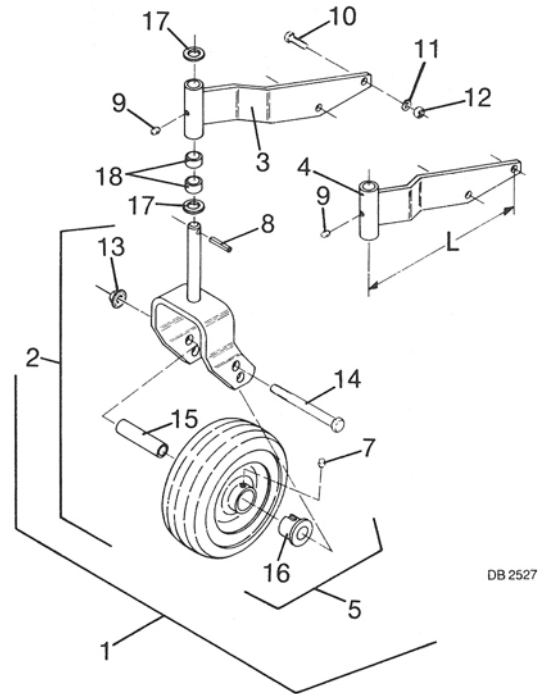

DB 2527

* Obtain locally, standard hardware

(a) For proper caster arm identification, refer to dimension "L" as shown on drawing. The caster arms may be used on either side to obtain best fit.

(b) Measure old bearing.

(c) Measure outside diameter of old sleeve.

MOWER FRAME ASSEMBLY

When reinstalling sheaves (19 & 22) on spindle shafts, the center of groove on right sheave should be 3-1/16" up from deck. The center of middle groove on center sheave 2-11/16" and the center of left sheave 2-7/16" above deck.

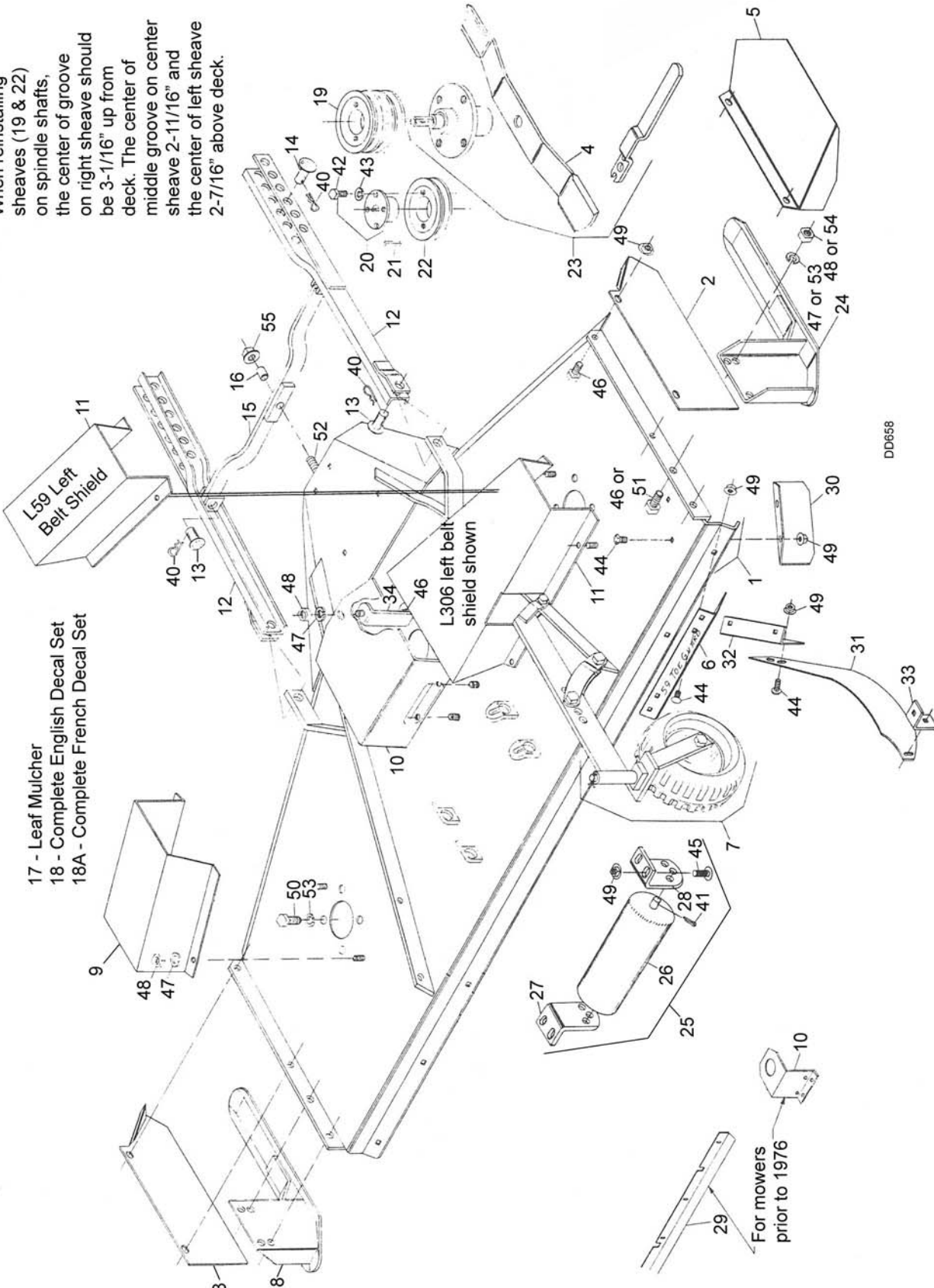

DD658

MOWER FRAME ASSEMBLY

REF	PART	QTY	DESCRIPTION	REF	PART	QTY	DESCRIPTION
1	9700	1	Frame only	25	24650	1	Front roller, complete (optional)
2	25513	1	Left side shield	26	24583	1	Front roller, bearing & rod
3	25512	1	Right side shield	27	24587	1	Left front roller bracket
4	6950KT	1	Blade, medium suction (std) -or-	28	24586	1	Right front roller bracket
4	26559KT	1	Blade, low suction (optional) -or-	29	5818	1	Front shield (for mowers prior to 1976)
5	26520	1	Side discharge chute	30	25508 †	1	Front corner baffle
				31	25509 †	1	Center baffle
				32	25532 †	1	Rear mounting angle
				33	25531 †	1	Front mounting lug
				34	25557 †	1	Center belt shield bracket
				40	2688 *		1/8 Safety pin
				41	1256 *		3/16 x 1 Cotter pin
				42	10378 *		1/4 NC x 1 HHCS GR5
				43	1985 *		1/4 Standard lock washer
				44	24597 *		3/8 NC x 3/4 Carriage bolt
				45	6697 *		3/8 NC x 1 Carriage bolt
				46	839 *		3/8 NC x 1 HHCS GR5
				47	838 *		3/8 Standard lock washer
				48	835 *		3/8 NC Hex nut, plated
				49	14350		3/8 NC Flange hex lock nut
				50	4119		1/2 NF x 1 HHCS GR5
				51	6100 *		1/2 NC x 1-1/4 HHCS GR5
				52	3699 *		1/2 NC x 2 HHCS GR5
				53	855 *		1/2 Extra-heavy lock washer
				54	1093 *		1/2 NC Heavy hex nut
				55	11900		1/2 NC Flange hex lock nut
							* Obtain locally, standard hardware
							† Mower frames sold after 1976 will have front of mower formed down. Before this time, mower had a bolt-on front shield.
							NOTES:
							(a) For all 59, L59 models except: GM2, LB, F10, F13, F15, H284, JD85, JD95, K17, K18, K210, K260, S, S55, S-BL, TB, YM.
							(b) For use on 59, L59 models: LB, K17, K18, K210, K260, S55, S-BL, TB, YM.
							(c) For F10, F13, F15, GM4, H284, JD85, JD95, S. See mounting frame assembly drawings for items 12 & 15.
6	26516	2	Front toe guard				
7	----	1	Castors, pair (optional)(see page 19)				
8	4141	1	Right side skid				
9	25506	1	Right belt shield				
10	25555	1	Center belt shield (use when front of mower is bent down) -or-				
10	4130	1	Center belt shield (use when front shield is bolted on mower)				
11	25507	1	Left belt shield				
12	13314	2	Channel arms (see notes a & c) -or-				
12	18241	2	Channel arms (see notes b & c)				
13	4097	4	5/8 x 1-1/2 Clevis pin				
14	410	2	5/8 x 1-3/4 Clevis pin				
15	3485	1	Crosswise rear support (see notes a & c) -or-				
15	18245	1	Crosswise rear support (see notes b & c)				
16	3504	1	1/2 x 5/8 x 1-1/16 Sleeve, HT				
17	----	1	Leaf mulcher (optional) (see page 22)				
18	5753	1	Complete decal set				
18A	52311	1	French safety decal set				
19	6126	1	Sheave (3-groove)				
20	4227	3	H3/4 Straight bushing with bolts				
21	3885 *	3	3/16 x 3/16 x 1-1/4 Key				
22	4226	2	Sheave (single-groove)				
23	----	3	Spindle, blade & wrench kit (white, left-hand blade rotation)(see page 18) -or-				
23	----	3	Spindle, blade & wrench kit (red or yellow, right-hand blade rotation)(see page 18)				
24	4142	1	Left side skid				

LEAF MULCHER

REF	PART	QTY	DESCRIPTION
A	7080	1	Leaf mulcher
1	-----	1	Leaf mulcher weldment (if part is worn out, order a complete new leaf mulcher)
2	7076	1	Angle lug
5	23218	1	3/8 Scdl 40 pipe 5/8 long (for use on 59's with bent down front frame)
7	839	*	3/8 NC x 1 HHCS GR5
8	25475	*	1/2 NC x 1 HHCS GR5
9	565	*	3/8 Flat washer
10	838	*	3/8 Lock washer
11	835	*	3/8 NC Hex nut

* Obtain locally, standard hardware

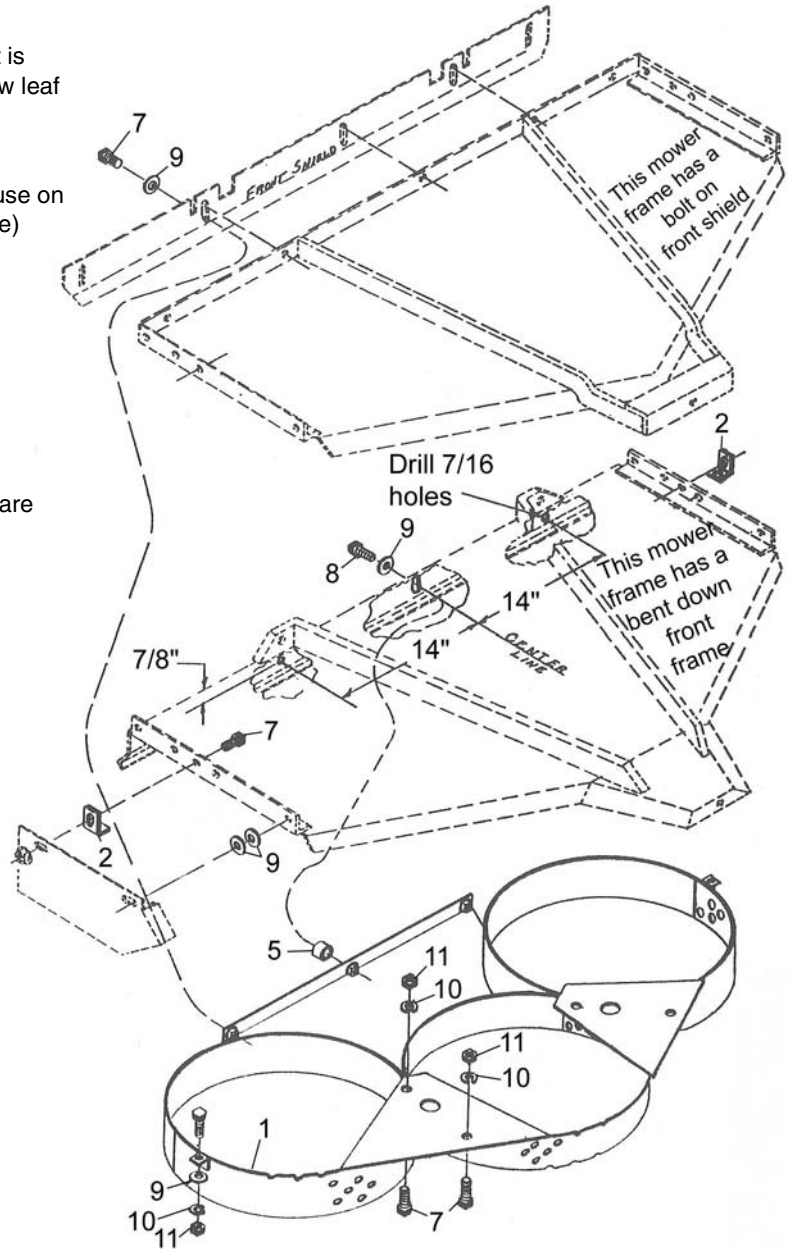

BOLT TORQUE CHART

Always tighten hardware to these values unless a different torque value or tightening procedure is listed for a specific application.

Fasteners must always be replaced with the same grade as specified in the manual parts list.

Always use the proper tool for tightening hardware: SAE for SAE hardware and Metric for metric hardware.

Make sure fastener threads are clean and you start thread engagement properly.

All torque values are given to specifications used on hardware defined by SAE J1701 MAR 99 & J1701M JUL 96.

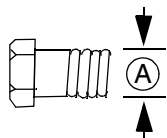

SAE SERIES TORQUE CHART



SAE Grade 2
(No Dashes)

SAE Bolt Head Identification



SAE Grade 5
(3 Radial Dashes)



SAE Grade 8
(6 Radial Dashes)

Ⓐ Diameter (Inches)	Wrench Size	MARKING ON HEAD					
		SAE 2		SAE 5		SAE 8	
		lbs-ft	N-m	lbs-ft	N-m	lbs-ft	N-m
1/4"	7/16"	6	8	10	13	14	18
5/16"	1/2"	12	17	19	26	27	37
3/8"	9/16"	23	31	35	47	49	67
7/16"	5/8"	36	48	55	75	78	106
1/2"	3/4"	55	75	85	115	120	163
9/16"	13/16"	78	106	121	164	171	232
5/8"	15/16"	110	149	170	230	240	325
3/4"	1-1/8"	192	261	297	403	420	569
7/8"	1-5/16"	306	416	474	642	669	907
1"	1-1/2"	467	634	722	979	1020	1383

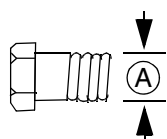

METRIC SERIES TORQUE CHART



8.8
Metric
Grade 8.8

Metric Bolt Head Identification



10.9
Metric
Grade 10.9

Ⓐ Diameter & Thread Pitch (Millimeters)	Wrench Size	Coarse Thread				Fine Thread				Ⓐ Diameter & Thread Pitch (Millimeters)
		Marking on Head				Marking on Head				
		Metric 8.8		Metric 10.9		Metric 8.8		Metric 10.9		
		N-m	lbs-ft	N-m	lbs-ft	N-m	lbs-ft	N-m	lbs-ft	
6 x 1.0	10 mm	8	6	11	8	8	6	11	8	6 x 1.0
8 x 1.25	13 mm	20	15	27	20	21	16	29	22	8 x 1.0
10 x 1.5	16 mm	39	29	54	40	41	30	57	42	10 x 1.25
12 x 1.75	18 mm	68	50	94	70	75	55	103	76	12 x 1.25
14 x 2.0	21 mm	109	80	151	111	118	87	163	120	14 x 1.5
16 x 2.0	24 mm	169	125	234	173	181	133	250	184	16 x 1.5
18 x 2.5	27 mm	234	172	323	239	263	194	363	268	18 x 1.5
20 x 2.5	30 mm	330	244	457	337	367	270	507	374	20 x 1.5
22 x 2.5	34 mm	451	332	623	460	495	365	684	505	22 x 1.5
24 x 3.0	36 mm	571	421	790	583	623	459	861	635	24 x 2.0
30 x 3.0	46 mm	1175	867	1626	1199	1258	928	1740	1283	30 x 2.0

Typical Washer Installations

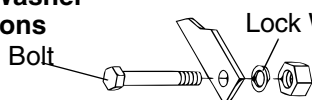

Lock Washer

Flat Washer

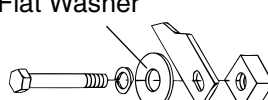

8/9/00

BOLT SIZE CHART

NOTE: Chart shows bolt thread sizes and corresponding head (wrench) sizes for standard SAE and metric bolts.

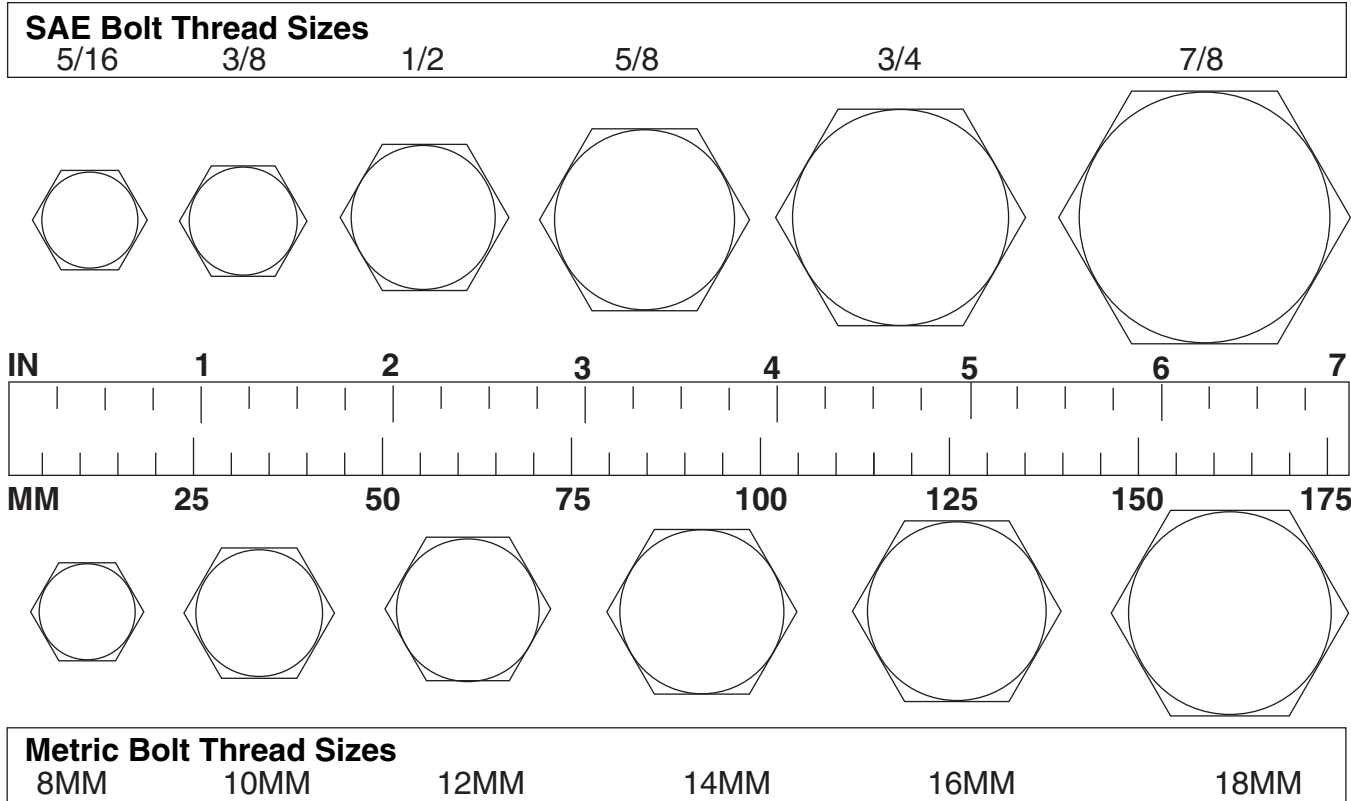

ABBREVIATIONS

AG Agriculture
 ASABE American Society of Agricultural & Biological Engineers (formerly ASAE)
 ASAE..... American Society of Agricultural Engineers
 ATF.....Automatic Transmission Fluid
 BSPP..... British Standard Pipe Parallel
 BSPTM..... British Standard Pipe Tapered Male
 CV Constant Velocity
 CCW..... Counter-Clockwise
 CW Clockwise
 F Female
 FT..... Full Thread
 GA Gauge
 GR (5, etc.)..... Grade (5, etc.)
 HHCS Hex Head Cap Screw
 HT Heat-Treated
 JIC..... Joint Industry Council 37° Degree Flare
 LH..... Left Hand
 LT Left
 m Meter
 mm Millimeter
 M Male

MPa Mega Pascal
 N Newton
 NC..... National Coarse
 NF National Fine
 NPSM National Pipe Straight Mechanical
 NPT.....National Pipe Tapered
 NPT SWF..... National Pipe Tapered Swivel Female
 ORBM O-Ring Boss - Male
 P Pitch
 PBY.....Power-Beyond
 psi Pounds per Square Inch
 PTO.....Power Take Off
 QD Quick Disconnect
 RH..... Right Hand
 ROPS..... Roll-Over Protective Structure
 RPM.....Revolutions Per Minute
 RT Right
 SAE..... Society of Automotive Engineers
 UNC Unified Coarse
 UNF Unified Fine
 UNS Unified Special

WARRANTY

(All Models Except Mow'n Machine™ Zero-Turn Mowers and Woods Boundary™ Utility Vehicles)

Please Enter Information Below and Save for Future Reference.

Date Purchased: _____ From (Dealer): _____
 Model Number: _____ Serial Number: _____

Woods Equipment Company ("WOODS") warrants this product to be free from defect in material and workmanship. Except as otherwise set forth below, the duration of this Warranty shall be for TWELVE (12) MONTHS COMMENCING ON THE DATE OF DELIVERY OF THE PRODUCT TO THE ORIGINAL PURCHASER.

Woods backhoe models BH70-X, BH80-X, and BH90-X are warranted for two (2) years from the date of delivery to the original purchaser.

The warranty periods for specific parts or conditions are listed below:

Part or Condition Warranted	Model Number	Duration (from date of delivery to the original purchaser)
Gearbox components	BW1260, BW1800	8 years
	BB48X, BB60X, BB72X, BB84X, BB600X, BB720X, BB840X, BB6000X, BB7200X, BB8400X, DS1260, DSO1260, DS1440, TS1680, BW126-2, BW180-2	6 years
	PHD25, PHD35, PHD65, PHD95, 2162, 3240, DS96, DS120, RCC42, RM550-2, RM660-2, RM990-3, PRD6000, PRD7200, PRD8400, 7144RD-2, 9180RD-2, 9204RD-2, S15CD, S20CD, S22CD, S25CD, S27CD	5 years
	RDC54, RD60, RD72	3 years (1 year if used in rental or commercial applications)
Blade spindles	RM550-2, RM660-2, RM990-3, PRD6000, PRD7200, PRD8400, 7144RD-2, 9180RD-2, 9204RD-2	3 years
Rust-through	BB600, BB720, BB840, BB6000, BB7200, BB8400, BW126-2, BW180-2, BW1260, BW1800, 2162, 3240, DS1260, DSO1260, DS1440, TS1680	10 years

Under no circumstances will this Warranty apply in the event that the product, in the good faith opinion of WOODS, has been subjected to improper operation, improper maintenance, misuse, or an accident. This Warranty does not apply in the event that the product has been materially modified or repaired by someone other than WOODS, a WOODS authorized dealer or distributor, and/or a WOODS authorized service center. This Warranty does not cover normal wear or tear, or normal maintenance items. This Warranty also does not cover repairs made with parts other than those obtainable through WOODS.

This Warranty is extended solely to the original purchaser of the product. Should the original purchaser sell or otherwise transfer this product to a third party, this Warranty does not transfer to the third party purchaser in any way. There are no third party beneficiaries of this Warranty.

WOODS makes no warranty, express or implied, with respect to engines, batteries, tires or other parts or accessories not manufactured by WOODS. Warranties for these items, if any, are provided separately by their respective manufacturers.

WOODS' obligation under this Warranty is limited to, at WOODS' option, the repair or replacement, free of charge, of the product if WOODS, in its sole discretion, deems it to be defective or in noncompliance with this Warranty. **The product must be returned to WOODS with proof of purchase within thirty (30) days after such defect or noncompliance is discovered or should have been discovered, routed through the dealer and distributor from whom the purchase was made, transportation charges prepaid.** WOODS shall complete such repair or replacement within a reasonable time after WOODS receives the product. **THERE ARE NO OTHER REMEDIES UNDER THIS WARRANTY. THE REMEDY OF REPAIR OR REPLACEMENT IS THE SOLE AND EXCLUSIVE REMEDY UNDER THIS WARRANTY.**

THERE ARE NO WARRANTIES WHICH EXTEND BEYOND THE DESCRIPTION ON THE FACE OF THIS WARRANTY. WOODS MAKES NO OTHER WARRANTY, EXPRESS OR IMPLIED, AND WOODS SPECIFICALLY DISCLAIMS ANY IMPLIED WARRANTY OF MERCHANTABILITY AND/OR ANY IMPLIED WARRANTY OF FITNESS FOR A PARTICULAR PURPOSE.

WOODS shall not be liable for any incidental or consequential losses, damages or expenses, arising directly or indirectly from the product, whether such claim is based upon breach of contract, breach of warranty, negligence, strict liability in tort or any other legal theory. Without limiting the generality of the foregoing, Woods specifically disclaims any damages relating to (i) lost profits, business, revenues or goodwill; (ii) loss of crops; (iii) loss because of delay in harvesting; (iv) any expense or loss incurred for labor, supplies, substitute machinery or rental; or (v) any other type of damage to property or economic loss.

This Warranty is subject to any existing conditions of supply which may directly affect WOODS' ability to obtain materials or manufacture replacement parts.

No agent, representative, dealer, distributor, serviceperson, salesperson, or employee of any company, including without limitation, WOODS, its authorized dealers, distributors, and service centers, is authorized to alter, modify, or enlarge this Warranty.

Answers to any questions regarding warranty service and locations may be obtained by contacting:

Woods Equipment Company

2606 South Illinois Route 2
 Post Office Box 1000
 Oregon, Illinois 61061

800-319-6637 tel
 800-399-6637 fax
 www.WoodsEquipment.com



- ALITEC™**
- BMP®**
- CENTRAL FABRICATORS®**
- GANNON®**
- GILL®**
- WAIN-ROY®**
- WOODS®**



WARRANTY

(Replacement Parts For All Models Except Mow'n Machine™
Zero-Turn Mowers and Woods Boundary™ Utility Vehicles)

Woods Equipment Company ("WOODS") warrants this product to be free from defect in material and workmanship for a period of ninety (90) days from the date of delivery of the product to the original purchaser with the exception of V-belts, which will be free of defect in material and workmanship for a period of 12 months.

Under no circumstances will this Warranty apply in the event that the product, in the good faith opinion of WOODS, has been subjected to improper operation, improper maintenance, misuse, or an accident. This Warranty does not cover normal wear or tear, or normal maintenance items.

This Warranty is extended solely to the original purchaser of the product. Should the original purchaser sell or otherwise transfer this product to a third party, this Warranty does not transfer to the third party purchaser in any way. There are no third party beneficiaries of this Warranty.

WOODS' obligation under this Warranty is limited to, at WOODS' option, the repair or replacement, free of charge, of the product if WOODS, in its sole discretion, deems it to be defective or in noncompliance with this Warranty. **The product must be returned to WOODS with proof of purchase within thirty (30) days after such defect or noncompliance is discovered or should have been discovered, routed through the dealer and distributor from whom the purchase was made, transportation charges prepaid.** WOODS shall complete such repair or replacement within a reasonable time after WOODS receives the product. THERE ARE NO OTHER REMEDIES UNDER THIS WARRANTY. THE REMEDY OF REPAIR OR REPLACEMENT IS THE SOLE AND EXCLUSIVE REMEDY UNDER THIS WARRANTY.

THERE ARE NO WARRANTIES WHICH EXTEND BEYOND THE DESCRIPTION ON THE FACE OF THIS WARRANTY. WOODS MAKES NO OTHER WARRANTY, EXPRESS OR IMPLIED, AND WOODS SPECIFICALLY DISCLAIMS ANY IMPLIED WARRANTY OF MERCHANTABILITY AND/OR ANY IMPLIED WARRANTY OF FITNESS FOR A PARTICULAR PURPOSE.

WOODS shall not be liable for any incidental or consequential losses, damages or expenses, arising directly or indirectly from the product, whether such claim is based upon breach of contract, breach of warranty, negligence, strict liability in tort or any other legal theory. Without limiting the generality of the foregoing, Woods specifically disclaims any damages relating to (i) lost profits, business, revenues or goodwill; (ii) loss of crops; (iii) loss because of delay in harvesting; (iv) any expense or loss incurred for labor, supplies, substitute machinery or rental; or (v) any other type of damage to property or economic loss.

This Warranty is subject to any existing conditions of supply which may directly affect WOODS' ability to obtain materials or manufacture replacement parts.

No agent, representative, dealer, distributor, service person, salesperson, or employee of any company, including without limitation, WOODS, its authorized dealers, distributors, and service centers, is authorized to alter, modify, or enlarge this Warranty.

Answers to any questions regarding warranty service and locations may be obtained by contacting:

Woods Equipment Company

2606 South Illinois Route 2
Post Office Box 1000
Oregon, Illinois 61061

800-319-6637 tel
800-399-6637 fax
www.WoodsEquipment.com

ALITEC™

BMP®

CENTRAL FABRICATORS®

GANNON®

GILL®

WAIN-ROY®

WOODS®